Arkenstall Village Centre
(Registered Charity No. 300394)
7 Station Road, Haddenham, Ely, Cambs CB6 3XD

Health and Safety Policy

1. General Statement of Policy

This document is the Health and Safety Policy of the Arkenstall Village Centre, Haddenham (the Centre).

- (a) Its policy is to:
 - i. Provide healthy and safe working conditions, equipment and systems of work for our employee(s), volunteers, trustees and users.
 - ii. Keep the village hall and equipment in a safe condition for all users.
 - iii. Provide such training and information as is necessary to employees, volunteers, trustees and hirers.
- (b) It is the intention of the Trustees of the Centre (the Committee) to comply with all health and safety legislation and to act positively where it can reasonably do so to prevent injury, ill health or any danger arising from its activities and operations.
- (c) The Committee considers the promotion of the health and safety of its employees at work and those who use its premises, including contractors who may work there, to be of great importance. The Committee recognises that the effective prevention of accidents depends as much on a committed attitude of mind to safety as on the operation and maintenance of equipment and safe systems of work. To this end, it will seek to encourage employees, volunteers, trustees and users to engage in the establishment and observance of safe working practices.
- (d) Employees, hirers and visitors will be expected to recognise that there is a duty on them to comply with the practices set out by the Committee, with all safety requirements set out in the hiring agreement and with safety notices on the premises and to accept responsibility to do everything they can to prevent injury to themselves or others.

2. Organisation of Health and Safety

- (a) The Management Committee has overall responsibility for health and safety at the Centre.
- (b) The Management Committee member with responsibility for the implementation and monitoring of health and safety policies is:
 - Name: Stuart Browse
 - e-mail: safety@arkenstallcentre.org.uk
- (c) Other people with specific health and safety responsibilities may be contacted as shown:
 - i. First Aid box: Facility Officer
 - ii. Reporting of accidents: safety@arkenstallcentre.org.uk
 - iii. Fire precautions and checks: safety@arkenstallcentre.org.uk
 - iv. Risk assessment and inspections including fire risk and evacuation procedures: safety@arkenstallcentre.org.uk
 - v. Information to contractors: safety@arkenstallcentre.org.uk
 - vi. Information to hirers: safety@arkenstallcentre.org.uk
 - vii. Insurance: safety@arkenstallcentre.org.uk
- (d) All employees, hirers and visitors have responsibility to take care of themselves and

others who may be affected by their activities and to co-operate with the Centre in keeping the premises, including the grounds, safe and healthy.

- (e) Should anyone using the Centre come across a fault, damage or other situation which might cause injury and cannot be rectified immediately they should inform the person named in 2(b) above, or the Facility Officer, as soon as possible so that the problem can be dealt with. Where equipment is damaged a notice should be placed on it warning that it is not to be used and it should be placed in the enclosed veranda at the back of the building. An entry should also be made in the equipment log kept next to the First Aid Box in the Kitchen.
- (f) A plan of the Centre showing the location of fire exits, fire extinguishers, fire alarm points etc forms part of the 'Fire Emergency – what to do' document at APPENDIX A.
- (g) A plan of the Centre showing the location of fuse boxes, gas cylinders and taps, stop cocks, boilers and loft accesses is at APPENDIX B.
- (h) A plan of the Centre showing the location of electricity cables and fuse boxes is at APPENDIX C.

3. Arrangements and Procedures

- (a) Fire Precautions and Checks
 - i. A copy of the risk assessment including the evacuation procedure and a map showing the fire exits, fire fighting equipment and assembly point is appended to this policy at APPENDIX A. This document is available on the AVC website and is given to all hirers.
 - ii. Details of the safety equipment service records are retained in the AVC's Operations Manual.
- (b) Procedure in case of accidents
 - i. The nearest hospital is the Princess of Wales Hospital at Lynn Road, Ely, CB6 1DN It has a minor injuries unit. The phone number is 01353 652000
 - ii. The nearest doctor's surgery is on The Green in Haddenham. The phone number is 01353 740205
 - iii. The First Aid Box is located in the Kitchen. If supplies are depleted notify the person named at 2(c)i above.
 - iv. The accident book is kept adjacent to the First Aid Box. This must be completed whenever an accident occurs.
 - v. Any accident must be reported to the person named at 2(c)ii above.
 - vi. The person responsible for completing RIDDOR (Reporting of Injuries, Diseases and Dangerous Occurrences Regulations 2013) forms and reporting accidents is named at 2(c)ii above.
 - vii. The following major injuries or incidents must be reported on RIDDOR forms:
 - fracture, other than to fingers, thumbs or toes
 - amputation
 - dislocation of the shoulder, hip, knee or spine
 - loss of sight (temporary or permanent)
 - any penetrating injury to the eye (including chemical)
 - injury from electric shock/burn leading to unconsciousness or requiring resuscitation or admittance to hospital for more than 24 hours;
 - any other injury leading to hypothermia, heat-induced illness or unconsciousness or requiring resuscitation or requiring admittance to hospital for more than 24 hours

-
- unconsciousness caused by asphyxia or exposure to harmful substance or biological agent
 - acute illness requiring medical treatment or loss of consciousness arising from absorption of any substance by inhalation, ingestion or through skin
 - acute illness requiring medical attention which may have resulted from a biological agent or its toxins or infected material.
- viii. Examples of reportable dangerous occurrences include:
- collapse or partial collapse of a scaffold over 5m high
 - unintended collapse of a building under construction or alteration, or of a wall or floor
 - explosion or fire
- (c) Safety Rules
- i. All hirers will be expected to read the Hiring Agreement, the Standard Conditions of Hire, the Information Sheet for Hirers and the Fire Evacuation Procedures (also at APPENDIX A of this document) all of which are on the AVC website at <http://www.arkenstallcentre.org.uk/hiring>, and should sign the Hiring Agreement as evidence that they agree to the hiring conditions. All new hirers will also be given information by the Caretaker or Committee Member introducing the Centre to the Hirer about safety procedures at the Centre which they will be expected to follow (e.g. fire evacuation procedures, use of trolleys to move equipment, use of equipment) and will be shown the location of the accident book and health and safety file.
- ii. Risk assessments are the responsibility of the person named at 2(c)iv above. This includes risk assessments on hazardous substances and fire. Any additional hazards identified through the risk assessment will be noted and procedures to be adopted in order to minimise risk will be recorded.
- iii. A full Risk Assessment is at APPENDIX D, and Risk Assessments relevant to Hirers are included in the Centre's Information Sheet for Hirers. In signing a Hiring Agreement, the Hirer confirms that he or she has read and understood the Information Sheet.
- (d) Contractors
- The Trustees will check with contractors (including self-employed persons) before they start work that:
- the contract is clear and understood by both the contractors and the committee;
 - they are competent to carry out the work e.g. have appropriate qualifications, references, experience;
 - they have adequate public liability insurance cover.
 - they have seen the health and safety file and are aware of any hazards which might arise (e.g. electricity cables or gas pipes).
 - they do not work alone on ladders at height (if necessary a volunteer should be present).
 - they have their own health and safety policy for their staff.
 - they know which member of the Management Committee is responsible for overseeing that their work is as asked and to a satisfactory standard.
 - any alterations or additions to the electrical installations or equipment must conform to the current regulations of the Institute of Electrical Engineers.

4. Insurance

The company providing the Centre's Employer's Liability and Public Liability insurance cover

is:

Zurich Insurance plc

Telephone no of insurer: 0800 917 9420

The following details may be obtained from the Treasurer:

Policy No and

Date of Renewal

5. Review of Health and Safety Policy

- (a) The Committee will review this policy annually. The review date is included in the schedule of regular agenda items.
- (b) Committee members with responsibility for aspects of health and safety will report to the Committee regularly. Their reports will include any accidents, faults, misuse by hirers or other matters which could affect the health and safety of users or employees.

APPENDIX A

Arkenstall Village Centre
(Registered Charity No. 300394)
7 Station Road, Haddenham, Ely, Cambs CB6 3XD

e-mail: bookings@arkenstallcentre.org.uk bookings phoneline: 07538 449677

Fire Emergency: What to do

At the first sign of a fire the Stewards will:

- a) If the fire is localised and its source is identifiable (eg a fire in a waste bin) **and** if the Stewards have had appropriate training in the use of fire extinguishers
- Use an appropriate extinguisher to put out the fire
- b) **IN ALL OTHER CIRCUMSTANCES** or if the fire is not immediately extinguished
- Activate the alarm if it has not already been activated
 - Guide all the attendees at the event to the nearest safe fire exit and to the Assembly Point. Any coats or personal belongings should be left, except if needed for medical or mobility reasons.
 - If it is safe to do so, check all three to be certain that there is nobody remaining in the building.
 - Telephone the Fire Brigade at any outbreak of fire, however slight.
PLEASE NOTE: There is no nearby public telephone.
 - Ensure that nobody attempts to re-enter the building, unless told that it is safe to do so by the by an Officer of the Fire Brigade.
 - Check attendees' names against the register if one is kept.
 - Ensure that no vehicles are moved unless they are obstructing the Fire Brigade or an Officer of the Brigade requires them to be moved.
 - Give the Facility Officer details of any fire and any call out of the Fire Brigade.

Stewards should practice Emergency Evacuation procedures once a year with their group

Fire safety – guidance for users of the Arkenstall Village Centre

1. The Hirer may take on the role of Fire Steward, and/or delegate that role to competent adults who will be present at the event. Stewards on duty must be easy to identify. There should be on the premises a minimum of:
 - Two stewards for up to 100 people
 - Three stewards for 100-200 people
 - Four stewards for more than 200 people

2. Before the start of any hiring the Hirer will ensure that Stewards receive instruction in the following matters:
 - The action to be taken in event of fire (see overleaf). This includes calling the Fire Brigade and evacuating the Premises safely to the Assembly Point adjacent to the re-cycling facilities in the car park.
 - The location and use of fire equipment (see attached plan).
 - Escape routes and the need to keep them clear (see attached plan).
 - Method of operation of escape door fastenings.
 - Appreciation of the importance of any fire doors and of closing all fire doors at the time of a fire.

3. At the start of any hiring, the Stewards shall check the following items:
 - That all fire exits are unlocked and panic bolts are in good working order.
 - That all escape routes are free of obstruction and can be safely used.
 - That any fire doors are not wedged open.
 - That exit signs are illuminated.
 - That there are no obvious fire hazards on the Premises.

4. During any hiring the Stewards shall ensure that:
 - All means of exit from the premises are kept free from obstruction and immediately available for instant free public exit.
 - The emergency lighting supply illuminating all exit signs and routes is turned on for the whole of the time the premises are occupied.

5. Further recommendations:
 - At a regular date and time a fire drill should be staged if practicable, with clubs who use the hall, so as to familiarise them with the procedure.
 - Wheelchair users to be positioned near the fire exits for the own safety.

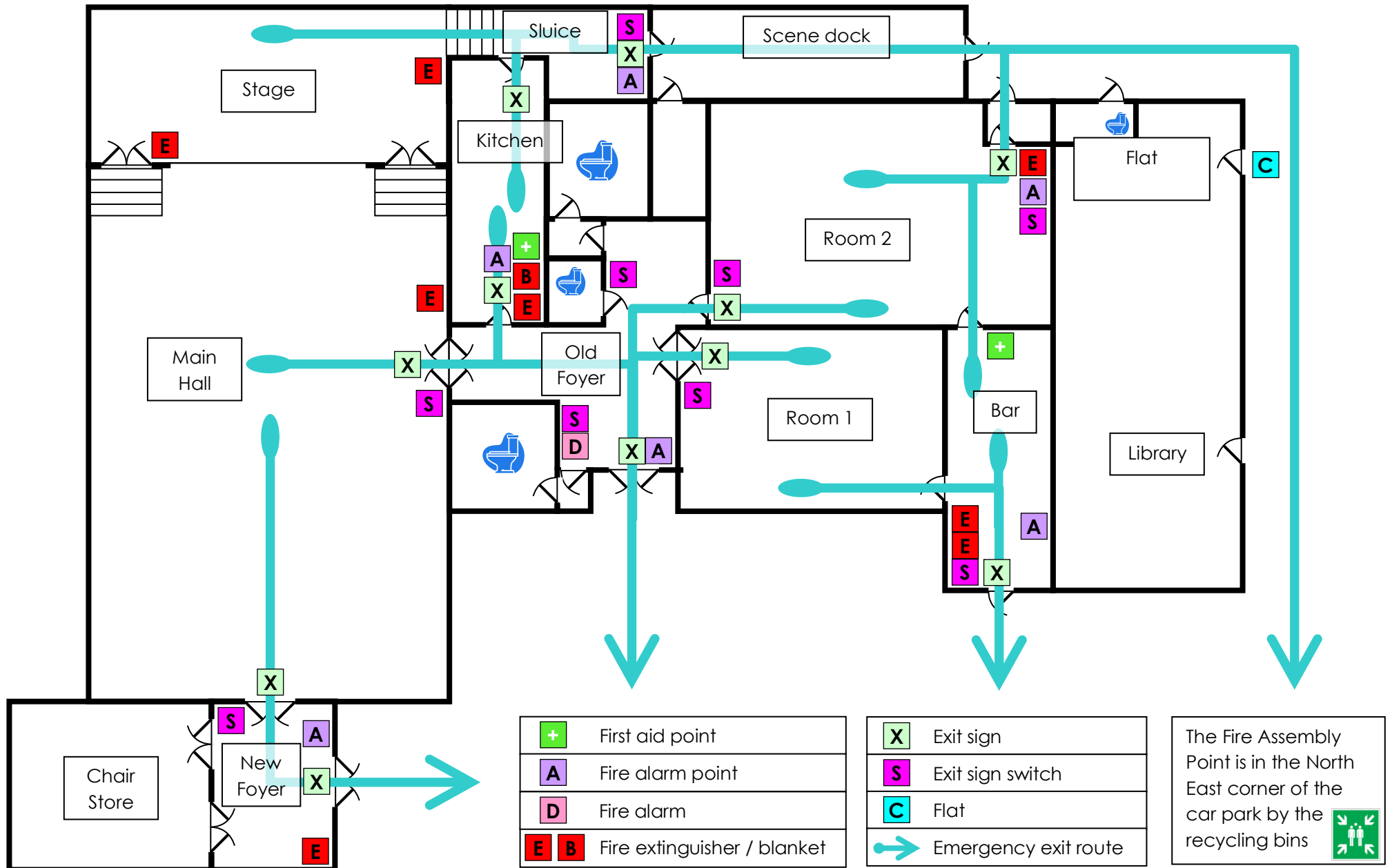

Document: AVC Fire Emergency – What to do
 Status: Final
 Date: 2023 08 07 – review 2024 08

Arkenstall Village Centre fire equipment and emergency exit routes

APPENDIX B

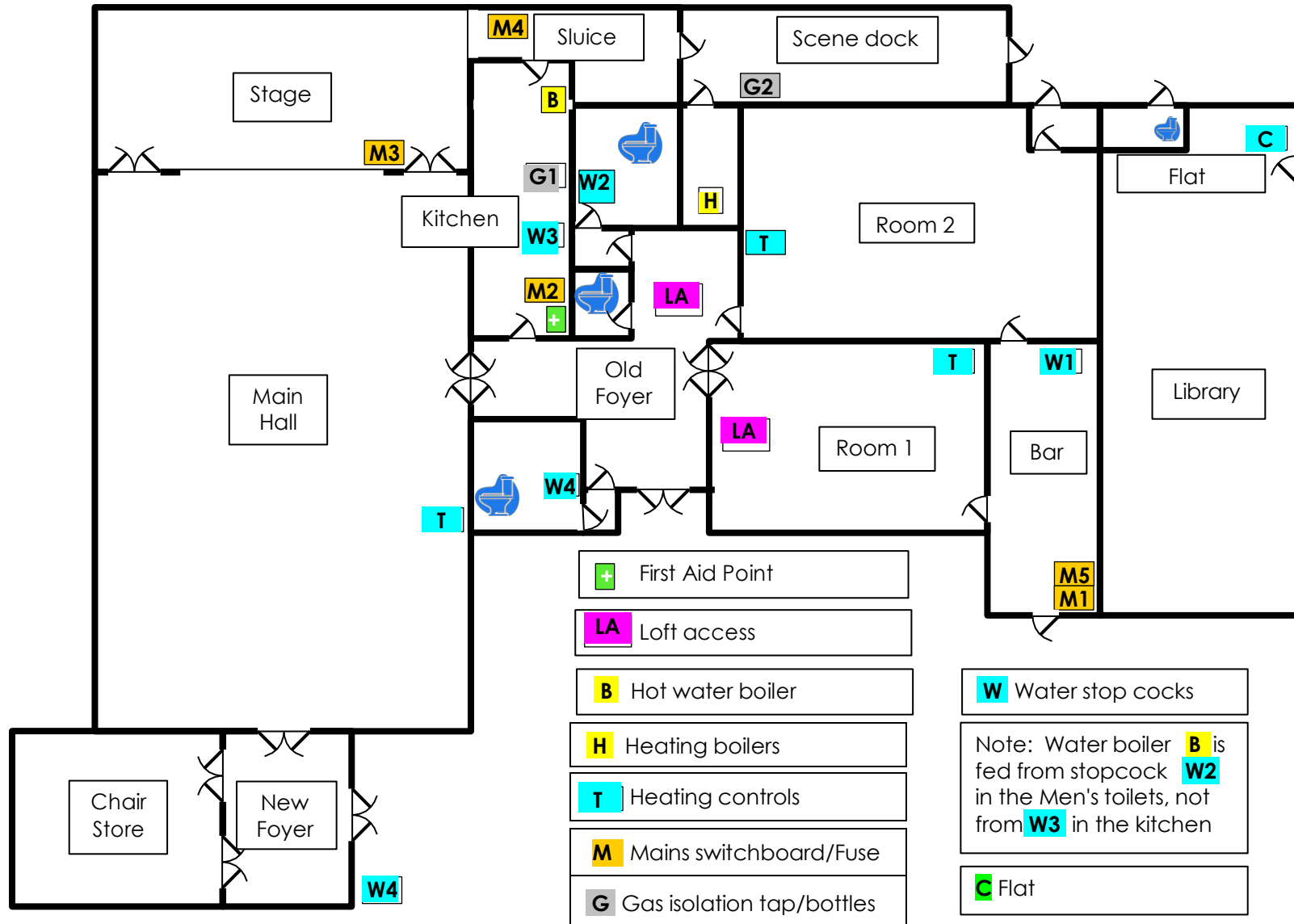

APPENDIX C

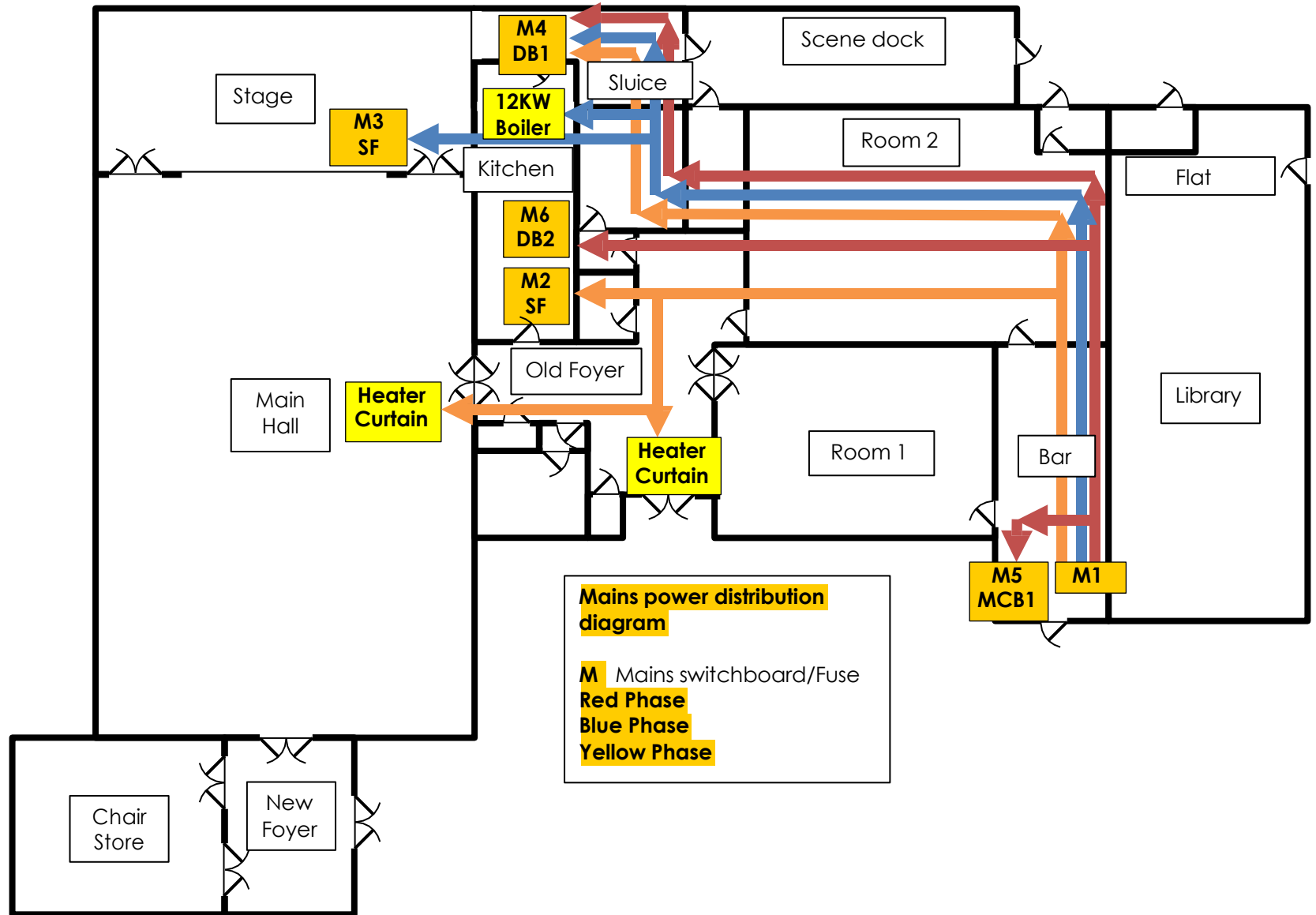

APPENDIX D

Full Risk Assessment

Notes:

- Where appropriate the identified risk and the appropriate control measures are listed in the Centre's Information Sheet for Hirers.
- In the following table 'Levels of Risk' are: L – Low, M – Medium, H – High

Risk Classification	Description of Risk	Persons at Risk	Level of Risk	Control Measures In Place	Further action to be taken and other notes
Operational	Inappropriate use of cleaning fluids and other chemical products kept on the premises.	Hirers, other visitors and volunteers	L	All materials are locked in cupboards in the Sluice Room	IN PLACE
	Cleaning and other toxic materials are stored and used.	Hirers, other visitors and volunteers	M	Wear suitable protective clothing when handling cleaning or other toxic materials.	Risk identified and advice and required action detailed in Information for Hirers.
	Tables and chairs are heavy to lift and move about the building.	Caretaker	M	Trolleys provided to enable tables to be wheeled between store room and hall.	IN PLACE
	Tables and chairs are heavy to lift and move about the building.	Hirers, other visitors and volunteers	M	Trolleys provided to enable tables to be wheeled between store room and hall. Use two people to set up room.	IN PLACE
	Emergency exit doors are blocked or locked during hirings.	Hirers, other visitors and volunteers	H	Make sure that all emergency exit doors are clear and unlocked as soon as the hall is to be used and throughout the hiring.	Risk identified and required action detailed in Information for Hirers.
	Damaged or wet electrical equipment could be used.	Hirers, other visitors and volunteers	M	Do not operate or touch any electrical equipment where there are signs of damage, exposure of components or water penetration etc.	Risk identified and required action detailed in Information for Hirers.

Document: AVC Health and Safety Policy
 Status: Final
 Date: 2023 08 07 – review 2024 08

	Unsecured steps or ladders may be unstable.	Hirers, other visitors and volunteers	M	Do not work on steps, ladders or at height until they are properly secured and another person is present.	Risk identified and advice and required action detailed in Information for Hirers.
	Portable electrical or gas appliances may be unsafe.	Hirers, other visitors and volunteers	M	Do not leave portable electrical or gas appliances operating while unattended.	Risk identified and advice and required action detailed in Information for Hirers.
	Portable electrical appliances which have not been Portable Appliance Tested (PAT) may be unsafe.	Hirers, other visitors and volunteers	L	Do not bring onto the property any portable electrical appliances which have not been Portable Appliance Tested.	Risk identified and advice and required action detailed in Information for Hirers.
	Stacks of chairs are awkward to manage and may be unstable.	Hirers, other visitors and volunteers	M	Do not stack more than 6 (six) red chairs or 10 (ten) green chairs. Do not move stacks of chairs without a trolley.	Risk identified and advice and required action detailed in Information for Hirers.
	Water boilers are heavy when full and awkward to move.	Hirers, other visitors and volunteers	M	Do not attempt to carry or tip a water boiler when it contains hot water. Leave it to cool.	Risk identified and advice and required action detailed in Information for Hirers.
	Unsupervised children may increase risk, particularly in the kitchen.	Hirers, other visitors and volunteers	M	Do not allow children in the kitchen except under close supervision (e.g. for supervised cookery lessons or, in the case of older children, for supervised serving of food at functions).	Risk identified and advice and required action detailed in Information for Hirers.
	In the kitchen there are gas cookers, electrical water boilers, and other equipment which may be hazardous if users are distracted.	Hirers, other visitors and volunteers	L	Avoid over-crowding in the kitchen and do not allow running.	Risk identified and advice and required action detailed in Information for Hirers.
	Damage or faults to equipment or the building's facilities may pose a risk to other users if not rectified.	Hirers, other visitors and volunteers	L	Report any evidence of damage or faults to equipment or the building's facilities in the 'Faults' book which is kept with the First Aid Box in the Kitchen].	Risk identified and advice and required action detailed in Information for Hirers.

	Slipping hazards on stairs, polished or wet floors.	Hirers, other visitors and volunteers	M	Avoid creating slipping hazards on stairs, polished or wet floors - mop spills immediately.	Risk identified and required action detailed in Information for Hirers.
	Tripping hazards such as buggies, umbrellas, mops and other items left in halls and corridors;	Hirers, other visitors and volunteers	M	Avoid creating tripping hazards.	Risk identified and required action detailed in Information for Hirers.
	Tripping in poorly lit areas.	Hirers, other visitors and volunteers	M	Use adequate lighting.	Risk identified and required action detailed in Information for Hirers.
	Issues relating to emergency communications while in sole occupancy of the building.	Hirers, other visitors and volunteers	M	Understand the risk to individuals while in sole occupancy of the building: carry a mobile phone whenever possible.	Risk identified and required action detailed in Information for Hirers.
	Toppling hazards by piling equipment e.g. in store cupboards.	Hirers, other visitors and volunteers	M	Stack equipment safely.	Risk identified and required action detailed in Information for Hirers.
Legal	All accidents must be reported: there is a risk that this obligation may not be met.	Hirers, other visitors and volunteers	L	Report every accident in the accident book and to the designated Committee Member.	Risk identified and required action detailed in Information for Hirers.
	Accidents to users on the premises	Trustees	M M	Public Liability Insurance taken out. Regular maintenance and repairs Accident book and First Aid kit available	DONE ONGOING DONE
	Disturbance of neighbours by hirers	Neighbours	M	Leaflet drops to close neighbours for one-off noisy events	ONGOING
External	Fire and emergency evacuation	Trustees, hirers, other visitors and volunteers	L	Fire precautions; alarm, signage & evacuation procedures are up-to-date and all users are fully informed	DONE

	Requisition of AVC in a local emergency under the Civil Contingencies Act 2014	Trustees and hirers	L	Nominate a trustee contact for the temporary requisition, inform all displaced hirers of the situation, continue to oversee the use and maintenance	ONGOING
Governance	Trustee/s make a mistake resulting in charity being sued	Trustees	L	Trustee Liability Insurance taken out: Policies will generally cover trustees for damages in civil court cases, although they will not protect them against fines in criminal cases. They can also protect trustees from debts incurred if the charity closes down and is unable to pay its bills.	DONE
	Staff long-term sickness	Trustees, hirers, other visitors and volunteers	L	Statutory sick pay can cover up to 28 days. Trustees would have to cover the role or pay for another to back-fill role during sickness.	DONE
	Insufficient trustees to run the Management Committee	Hirers	L	After the Management Committee has been wound up the Charity Haddenham Parish Council, as the Custodian Trustee under the Trust Deed of 12th July 1971, would take back the management of the premises	IN PLACE
Financial	Trustees make decisions without full knowledge of accounts	Trustees	L	Quarterly accounts are provided and discussed at management meetings	ONGOING
Compliance with laws and regulations	Charity Law	Trustees	L	Keep Charity Commission informed of any changes (Trustees, constitution etc.), comply with relevant financial reporting practices	ONGOING
	Employment Law	Trustees	M	Ensure employees rights are embedded in policies and practice	IN PLACE
	Equalities Law	Trustees	L	Adopt an Equalities policy and review regularly	ONGOING

Document: AVC Health and Safety Policy
Status: Final
Date: 2023 08 07 – review 2024 08

	Health & Safety Law	Trustees	L	Undertake regular fire-risk and operational risk assessments	ONGOING
	Food Standards Agency	Trustees	L	Ensure provision of equipment and information is available for all users to maintain (or improve) Food Hygiene Standards	IN PLACE
	Local licensing Law (e.g. entertainment and alcohol)	Trustees	L	One Trustee to act as Premises License holder and hirers to apply for their own temporary events notices and licenses	IN PLACE